

# SP 300 SQUEEGEE MACHINE

## Operating Instructions & Parts Manual



**SealMaster®**  
  
Pavement Products & Equipment

PO Box 2277 • Sandusky, Ohio 44870 • 419-626-4375

**SealMaster®**

# ThorWorks Industries, Inc.

Purchased by \_\_\_\_\_ Model NO. \_\_\_\_\_  
Company Name \_\_\_\_\_ Serial NO. \_\_\_\_\_  
Address \_\_\_\_\_ Acceptance Date \_\_\_\_\_  
City \_\_\_\_\_ State \_\_\_\_\_ Zip \_\_\_\_\_

## CORRESPONDENCE

All Correspondance regarding this equipment, as well as general correspondence should be addressed to:

ThorWorks Industries, Inc.  
PO Box 2277  
Sandusky, OH 44870

In referring to the equipment, kindly state the Model Number, Serial Number and any part number involved

**THORWORKS**<sup>INDUSTRIES</sup>

CALIFORNIA

Proposition 65 Warning

Diesel engine exhaust and some of its constituents are known to the State of California to cause cancer, birth defects, and other reproductive harm.

## SealMaster Limited Warranty

SealMaster warrants that its products are of quality material and workmanship. SealMaster agrees to replace, within a period of one (1) year from date of delivery, or at its option, repair, without charge, any part of their manufacture which proved defective. The repair or replacement will be free of charge F.O.B Sandusky, Ohio, proving the damaged part or parts are returned, freight prepaid, to SealMaster and investigation show such repair or replacement is made necessary by inherent defect of material or workmanship.

It is hereby understood that engines, motors, pumps, or other components purchased by SealMaster for use on its equipment are not warranted by SealMaster and are sold only with the standard warranty of the manufacturer of that component.

SealMaster will make no allowances for repairs or alterations completed by outside sources unless authorization is in writing and approved by an authorized SealMaster representative.

Any claims for defective material or workmanship must be made prior to the expiration of thirty (30) days from the date failure occurs, and in all cases prior to the expiration of the warranty period of one (1) year. It is the intent of this paragraph to limit SealMaster's liability solely to the cost of replacement parts, F.O.B. factory, or at the option of SealMaster to repair of the defective part or parts. No allowances for damages, lost time, or any other claim will be recognized.

This warranty is null and void if other than genuine SealMaster parts are used.

SealMaster is constantly striving to improve their products. Changes in design and improvement will be made whenever the manufacturer believes the efficiency of the product will be improved, without incurring any obligation to incorporate such improvements in any machines which have been shipped or are in service.

In an effort to continue to improve product quality, SealMaster reserves the right to change specifications without notice.

Any modification or alteration of this machine without prior approval of the manufacturer may void this warranty.

# **TANK CHART FOR SP300**

(DIMENSIONS ARE 42" DIAMETER X 53" LONG)

TOTAL CAPACITY 318 GALLONS

Material Depth (inches)	Gallons	Material Depth (inches)	Gallons	Material Depth (inches)	Gallons
42	318	28	225	14	93
41	316	27	217	13	84
40	312	26	207	12	75
39	308	25	196	11	66
38	303	24	187	10	59
37	296	23	179	9	50
36	290	22	169	8	42
35	284	21	159	7	34
34	276	20	149	6	28
33	268	19	139	5	22
32	259	18	131	4	15
31	252	17	122	3	10
30	243	16	111	2	6
29	234	15	101	1	2

## **IMPORTANT:**

Before operating your new SealMaster machine:

1. Read the operating instructions and all component manuals.
2. Check all nuts, bolts, and set screws for tightness. The nuts, bolts, and set screws are machine tightened before leaving the factory, however, some loosening may occur during shipment.
3. Read maintenance instructions.

## **MAINTENANCE:**

### A. ENGINE OIL:

1. Change engine oil frequently. Follow the instructions in the engine manual for type and changing schedule.

### B. HYDRAULIC OIL:

1. Check the hydraulic oil level before each day of operation. The proper level is 6 inches below the top of the tank.
2. Hydraulic oil should be changed at least once each year. Use grade 68, ASTM Grade 315, viscosity 330 SUS 100° F Hydraulic oil.

### C. Read the following operating procedures and maintenance schedule as listed in the respective manuals provided for the engine, motors, pumps, and valves.

### D. BEARINGS:

1. All bearings should be greased once every month.
2. Check the tightness of all set screws.

### E. FRONT STEERING SHAFT:

1. Grease the steering shaft weekly. Inspect the bearings yearly.

### F. TIRES:

1. Always check air pressure.
2. Check tightness of lug nuts. Torque to 90 lbs. ft.

### G. AFTER WORK MAINTENANCE:

1. Refer to water flush instructions discussed later in this manual.
2. Do not let material set in material tank for more than two days without removing or agitating.

## **BEFORE STARTING ENGINE:**

1. Follow the maintenance procedures listed in the engine manual.
2. Check the gas supply.
3. Make sure the forward/reverse lever, located at the left of the steering wheel, is in the neutral position.
4. Make sure all valves are closed and the toggle switches are to the off position.

### **CAUTION**

Do not operate the engine with the shrouds removed.

Do not place hands or solid objects into material hopper with the engine running.

## **TO START ENGINE:**

1. Position yourself in the operator's seat.
2. Pull the throttle handle, located to the right of the steering wheel, 1/3 of the way up.
3. **COLD ENGINE** — Pull choke knob, located on the control panel, in front of the steering wheel, all of the way out and turn the key switch, if the engine does not start, repeat this procedure. Use the choke moderately. Allow the engine to warm up before operating.
4. **WARM ENGINE** — It should not be necessary to use the choke when the engine is warm. However, this may vary with each engine. This will require the operator to become familiar with the unit.

## **TO OPERATE MACHINE:**

1. To move the machine forward, push forward/reverse control lever 42 forward SLOWLY, until your desired speed is reached. To move the machine in reverse, pull the lever to neutral, then to the reverse position.

**NEVER OPERATE MACHINE IN REVERSE WITH  
REAR ASSEMBLY IN THE DOWN POSITION!!!**

## **FILLING MATERIAL TANK:**

1. When cutting material in the machine, always place sealer in the tank before adding water.
2. Start the agitator by moving valve lever H-10 to the forward position. The farther you move the lever the faster the agitator will rotate. After mixing, bring the lever back towards neutral so that the agitator is rotating slowly.
3. To avoid build up of sand on the sides of the machine, always pour sand into the center of the tank. The usual amount of sand used to provide an anti-skid surface or to fill porous pavement is three (3) pounds per gallon of sealer. This will vary according to the porosity of the surface you are sealing.



## **OPERATING WATER FOG BAR:**

**CAUTION: NEVER RUN WATER**

**PUMP WITH WATER TANK EMPTY!!!**

1. During very hot weather a better adhesion of sealer to blacktop can be obtained by use of the water fog bar. Water spray will cool down the asphalt and help mix any dust missed during the cleaning operation. The water tank fill is located under the left side step. Always use clean water to avoid plugging water lines.
2. Engage water toggle switch Z, labeled water pump, to the UP position.
3. Hold in on the button above the water toggle switch Q until the water starts to spray out. This activates the pump pressure safety switch which will stop when the water tank runs dry.

## **SQUEEGEE APPLICATION OF SEALER:**

1. Lower the rear end assembly by moving the valve lever H-14, labeled rear assembly UP-DOWN, to down position.
2. Place your feet on the peddles and press down with the heel part of your foot to open valves. Press with your toe to close the valves. Keep sealer in a roll of 1 to 3 inches for a full 90 inch application. If you are sealing on a hill going horizontal, use only the flow control valve toward the top of the hill. This will prevent material from running out of the forward squeegee box.
3. The rear squeegee can be angled left or right by squeezing the lever to the left of the seat, and pushing forward or pulling back. Angling the squeegee allows the operator to leave a "wet" edge on extremely long pulls.

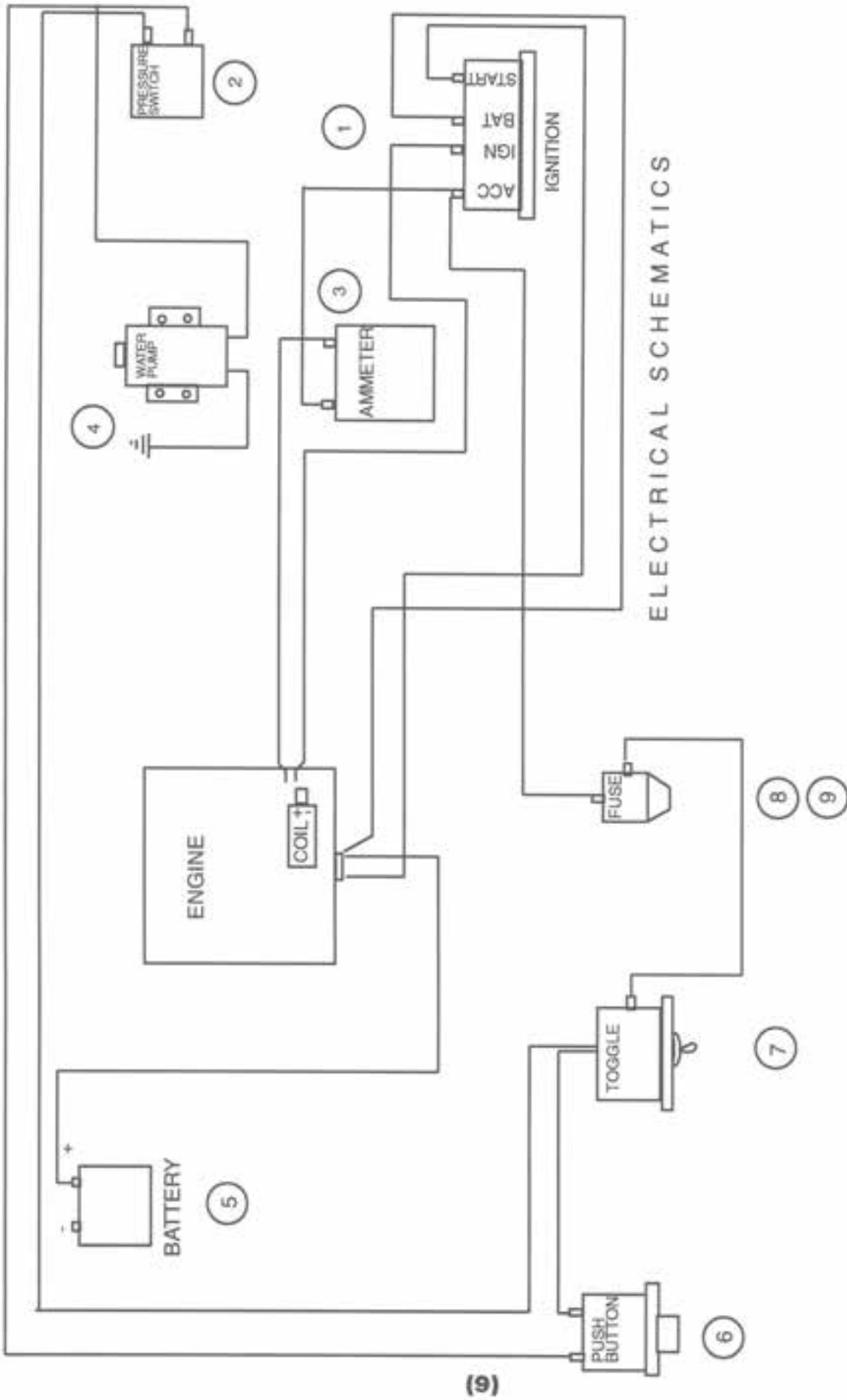

## **ELECTRICAL SCHEMATICS:**

1.	P442A001	—	Ignition Switch
2.	P914A001	—	Pressure Switch
3.	P440A001	—	Ammeter
4.	P593A001	—	Water Pump
5.	P466A001	—	Battery
6.	P916A001	—	Push Button Switch
7.	P443A001	—	Toggle Switch
8.	P461A001	—	Fuse Holder
9.	P595A001	—	10 amp Fuse
10.	P596A001	—	Water Tank
11.	P449A001	—	6503 Spray Tip

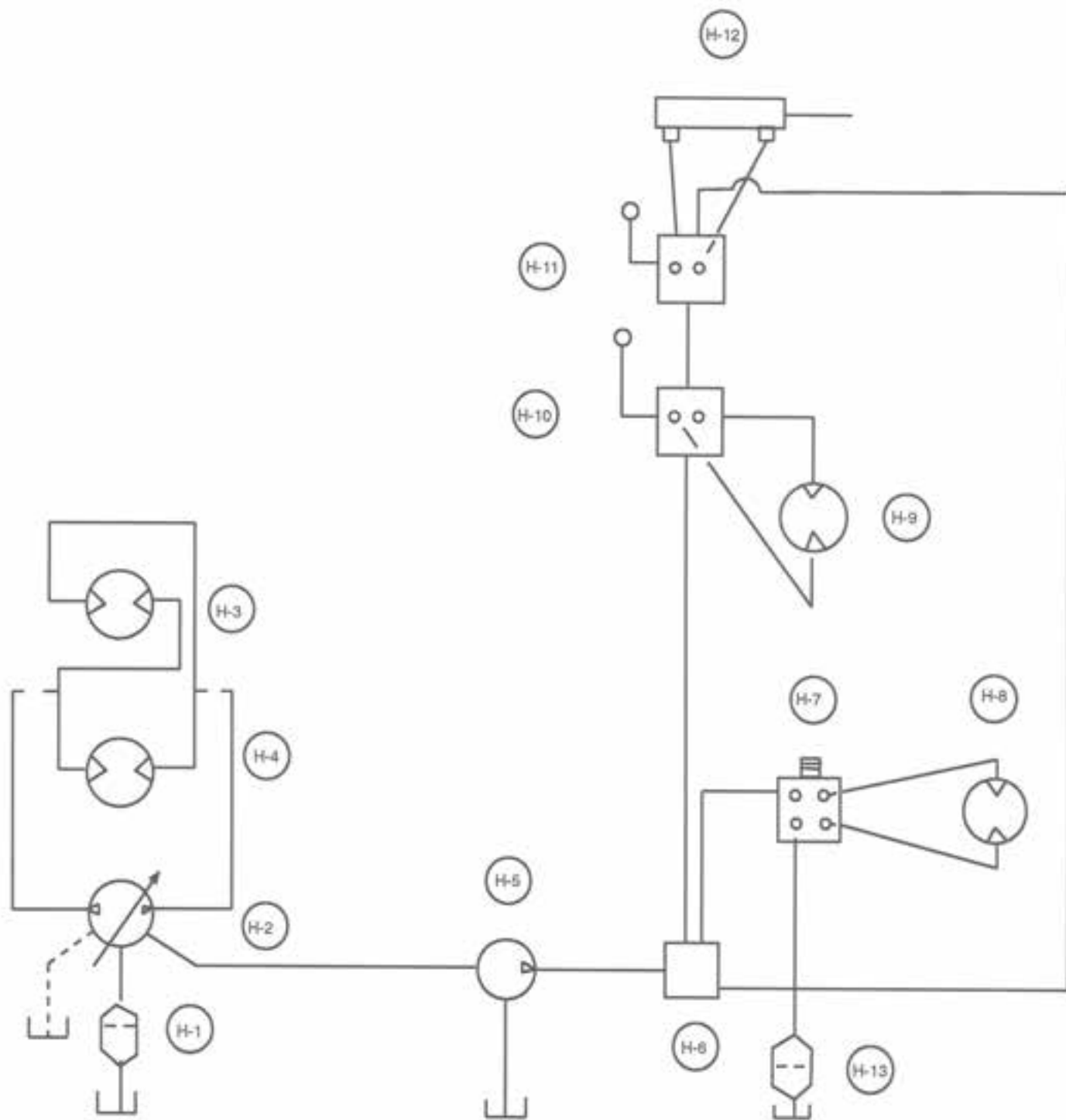

## **HYDRAULICS SCHEMATICS:**

H-1	P908A005	—	Suction Line Filter
H-2	P707A002	—	Transmission
H-3	P474A022	—	Left Rear Drive Motor
H-4	P474A023	—	Right Rear Drive Motor
H-5	P601A020	—	Gear Pump
H-6	P700A003	—	Flow Divider
H-7	P936A001	—	Steering Control
H-8	P474A004	—	Steering Motor
H-9	P474A004	—	Agitator Motor
H-10	P472A010	—	Agitator Control Valve
H-11	P472A002	—	Squeegee Assembly Up-down Valve
H-12	P600A005	—	Up-down Cylinder
H-13	P908A003	—	Return Line Filter

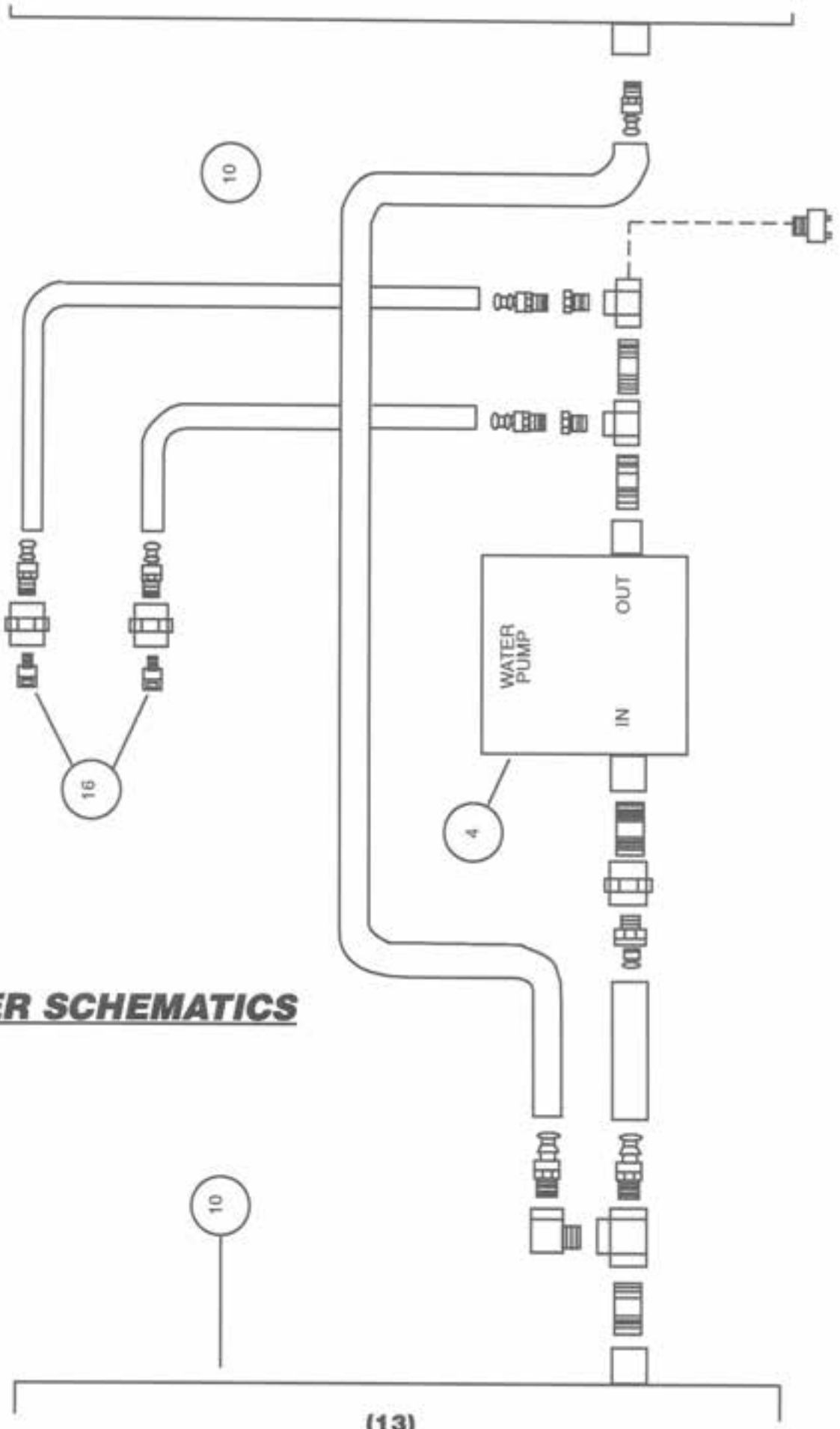

**WATER SCHEMATICS**

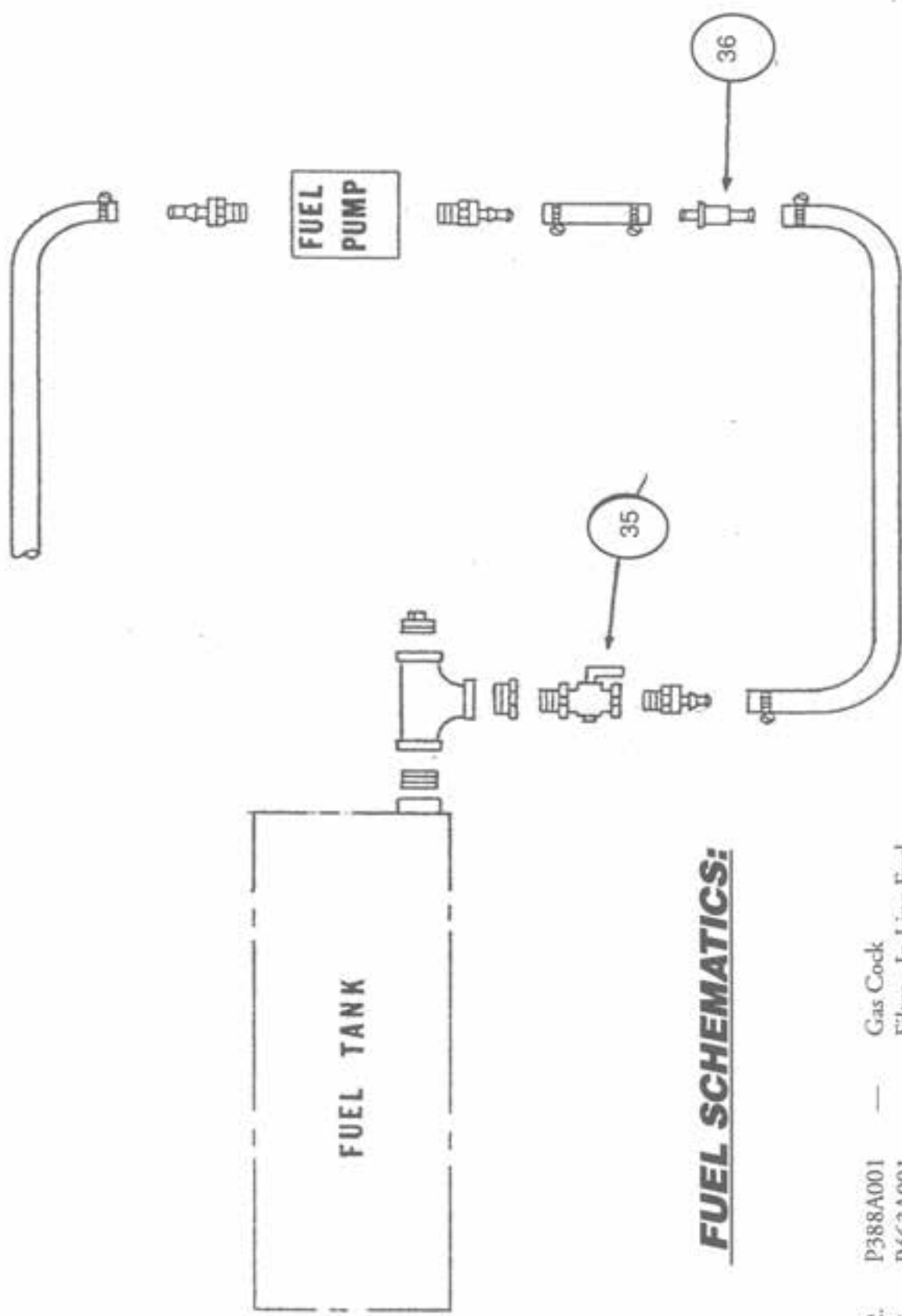

**FUEL SCHEMATICS:**

- 12. P388A001 — Gas Cock
- 13. P463A001 — Filter - In Line Fuel



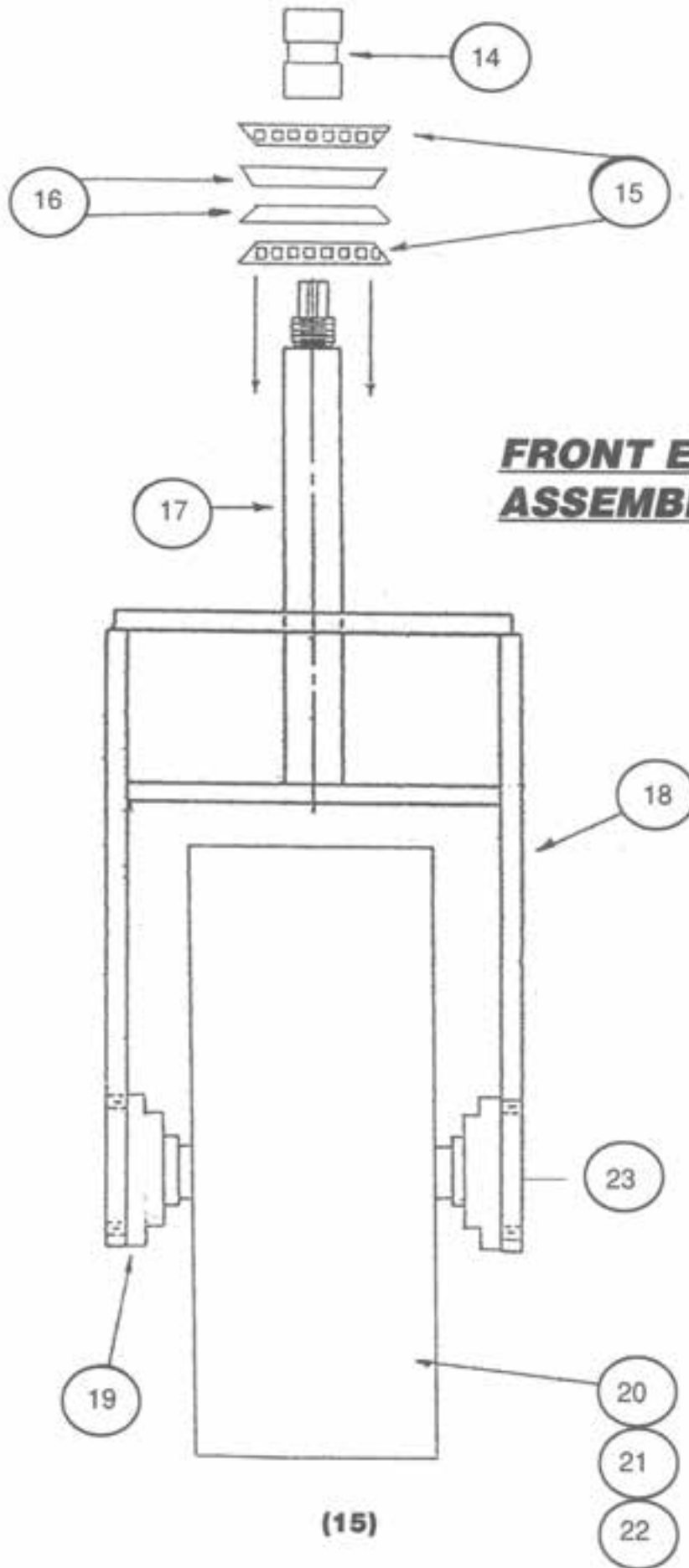

**FRONT END ASSEMBLY:**

(15)

## **FRONT END ASSEMBLY:**

14.	P498A004	—	Front Drive Coupling
15.	P476A004	—	Inner Race Bearing
16.	P476A005	—	Outer Race
17.	P360B	—	Center Shaft - Steering Fork
18.	P345B	—	Weldment - Front Fork w/Shaft
19.	P432A003	—	Bearing - 2 Hole Flange - 1¼"
20.	P576A007	—	Tire Only
21.	P574A002	—	Tire Tube
22.	P577A004	—	Wheel
23.	P354B	—	Front Axle Weldment

## **SHEMATICS:**

24.	P602A001	—	Seat
25.	P496A002	—	Steering Wheel
26.	P29899A	—	Rubber Seal
27.	P432A003	—	Bearing - 2 Hole Flange 1¼"
28.	P382A	—	Shaft for Agitator
29.	P380C	—	Agitator
30.	P514A002	—	Tire and Wheel Complete
31.	P577A004	—	Split Rim
32.	P579A003	—	Lug Nuts
33.	P488B	—	Choke Cable with Knob
34.	P488T	—	Throttle Cable and Conduit - T Handle
35.	P464A001	—	Locking Gas Cap
36.	P579A002	—	Lug Bolts

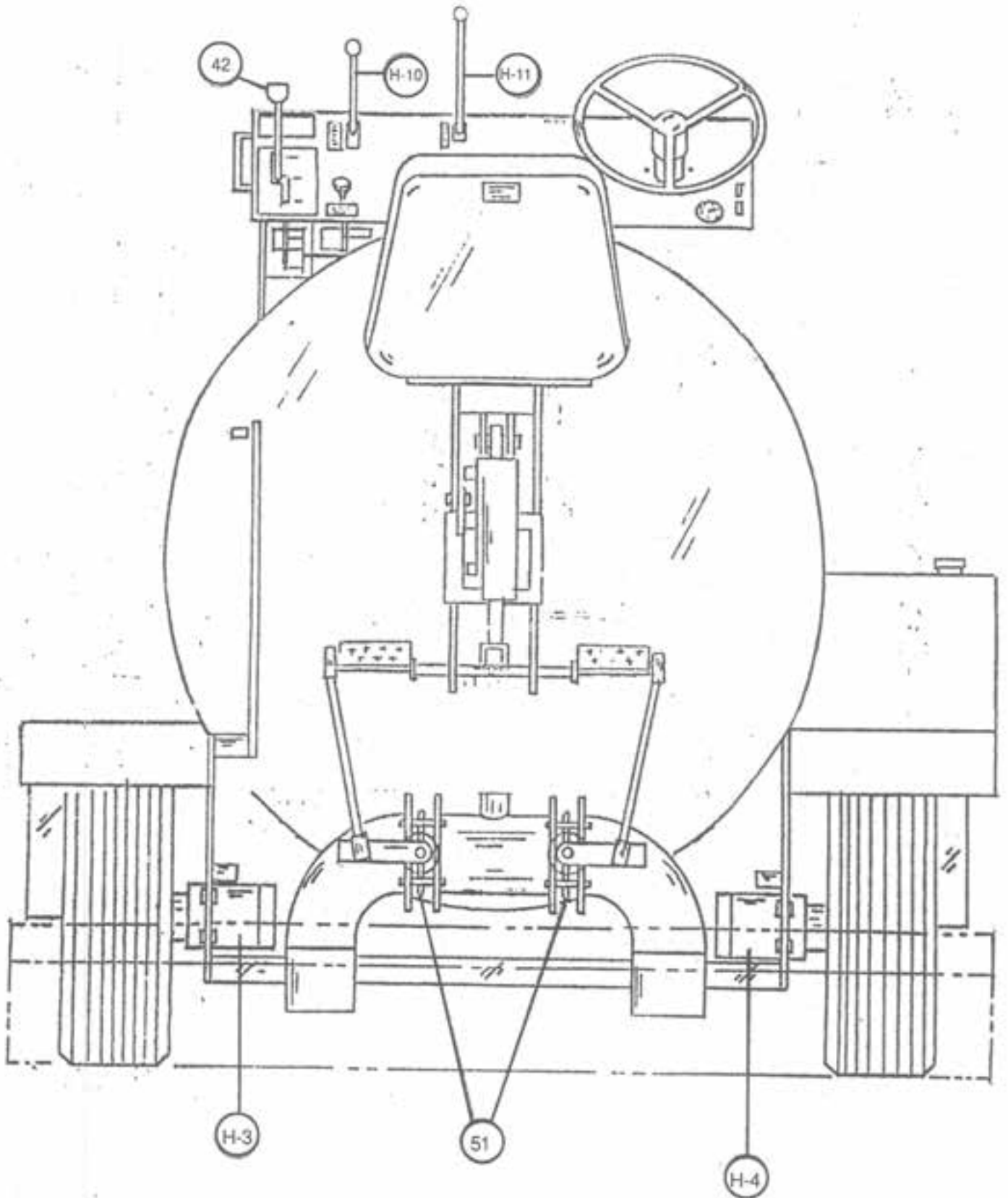

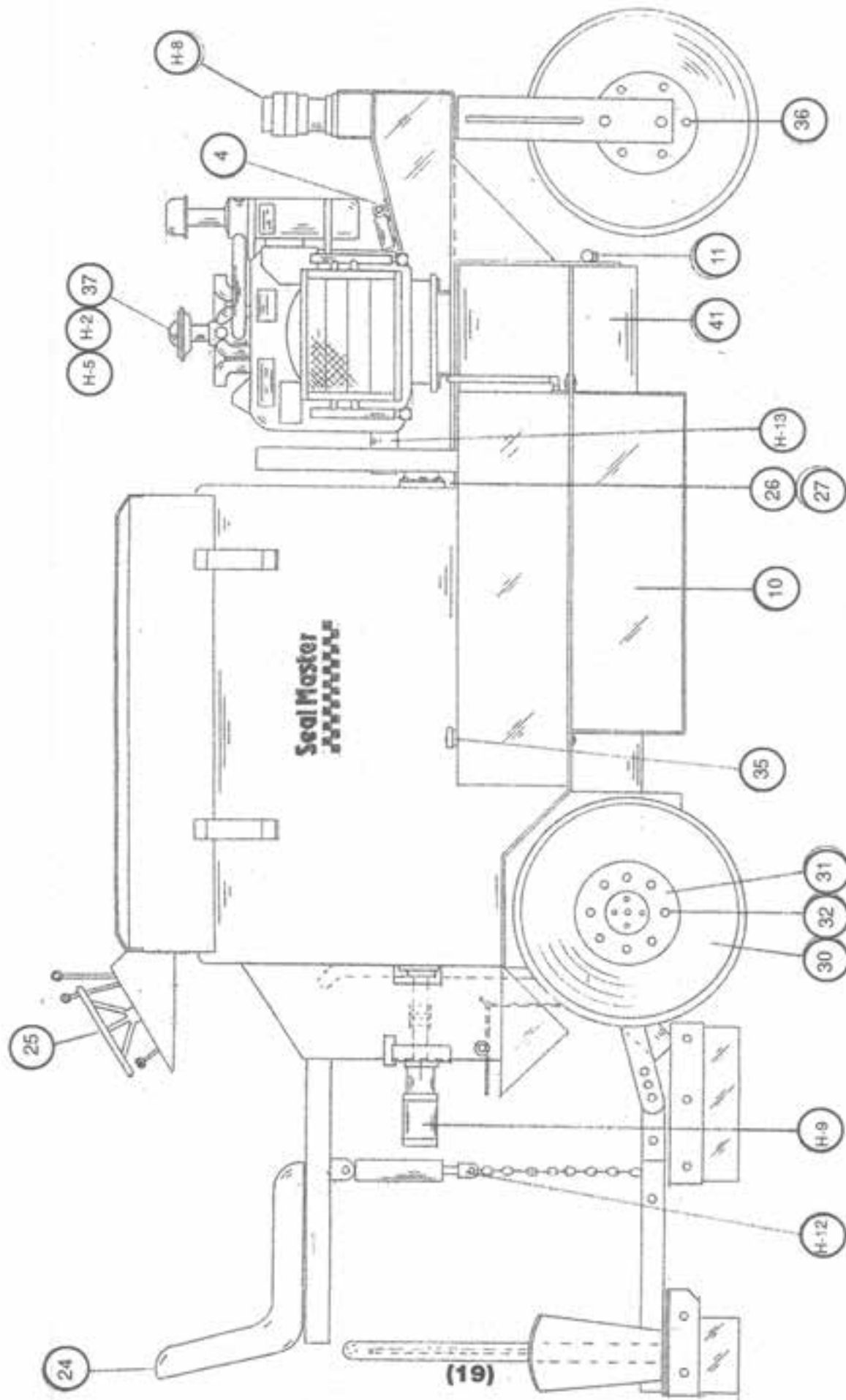

37.	P458A017	—	30 HP Wisconsin Engine
38.	P630A013	—	5016 Chain Coupling (On Wisconsin Engine)
39.	P630A011	—	5016 Chain Coupling (On Transmission)
40.	P631A002	—	5016 Replacement Chain
41.	P938A009	—	Hydraulic Oil
42.	P488A001	—	Forward - Reverse Control

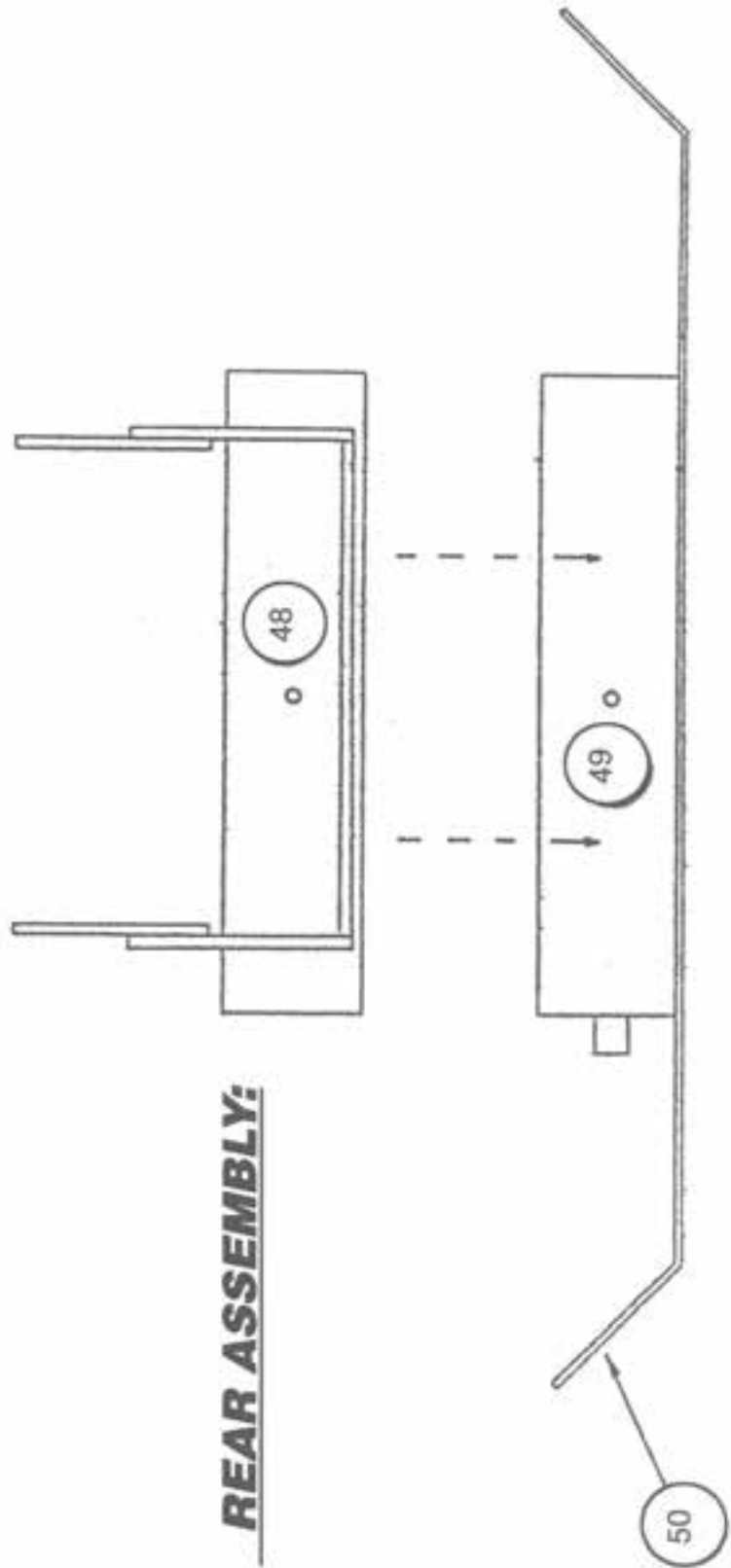
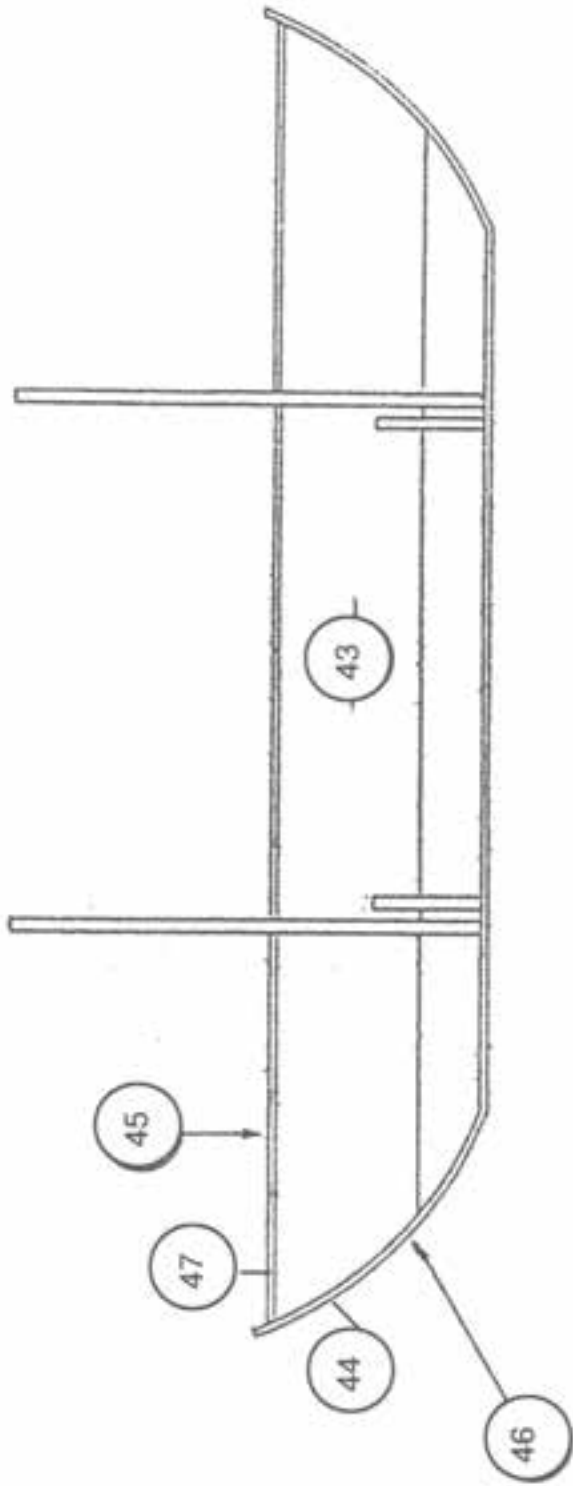

**REAR ASSEMBLY:**

43.	P70001	—	Box Assembly Frame
44.	P109A	—	Back Up Strip x 90" (Also for Rear Assembly)
45.	P109B	—	Back Up Strip x 78"
46.	P459A003	—	3/8" x 6" x 90" Neoprene Rubber
47.	P459A012	—	3/8" x 6" x 80" Neoprene Rubber
48.	P70002	—	Top Rear Assembly Frame
49.	P70003	—	Bottom Rear Assembly Frame
50.	P459A009	—	1/2" x 6" x 90" Neoprene Rubber
51.	P398A009	—	3" Butterfly Valve



## **HOW TO WINTERIZE YOUR EQUIPMENT:**

1. Remove the drain plug on the water tank. On the electric water pump, remove the face plate.
2. Disconnect the battery and take it inside if your machine will remain outdoors.
3. Cover the engine with a plastic trash bag.
4. Also put a plastic sandwich bag around each locking cap.
5. If any cylinder rods are exposed, put a thin layer of grease on them.